

ENCODER	
VOLTAGE	+5 VDC ±5%
CURRENT	max. 200 mA
FREQUENCY	0 - 125 kHz
TEMP.	-20 - 40 °C
RESOLUTION	2500

Encoder connector - D-SUB HD 15 PIN

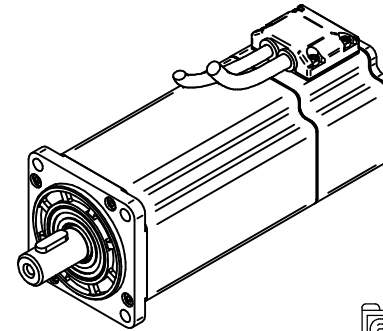
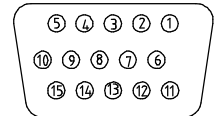

ENCODER CONNECTIONS		
Pin	Color	Signal
1	red	+5V
2	blk	GND
3	-	-
4	brn/blk	U+
5	brn	U-
6	yel	Z+
7	grn	B+
8	blu/blk	A+
9	gry/blk	W+
10	wht/blk	V+
11	yel/blk	Z-
12	grn/blk	B-
13	blu	A-
14	gry	W-
15	wht	V-

Motor Specification	
Voltage	300 VDC
Rated Power	400 W
Rated Speed	3000 rpm
Rated Current	3.1 A
Rated Torque	1.27 Nm
Peak Current	9.3 A
Peak Torque	3.81 Nm
Number of Poles	6
Resistance	3.52 Ohm ±10%
Inductance	7.8 mH ±20%
Ke (RMS)	29 V/Krpm
Kt	0.48 Nm/A
Rotor Inertia	0.51 kgcm ²
Weight	1.8 kg
Max Radial Force	180 N
Max Axial force	90 N

Performance Curve

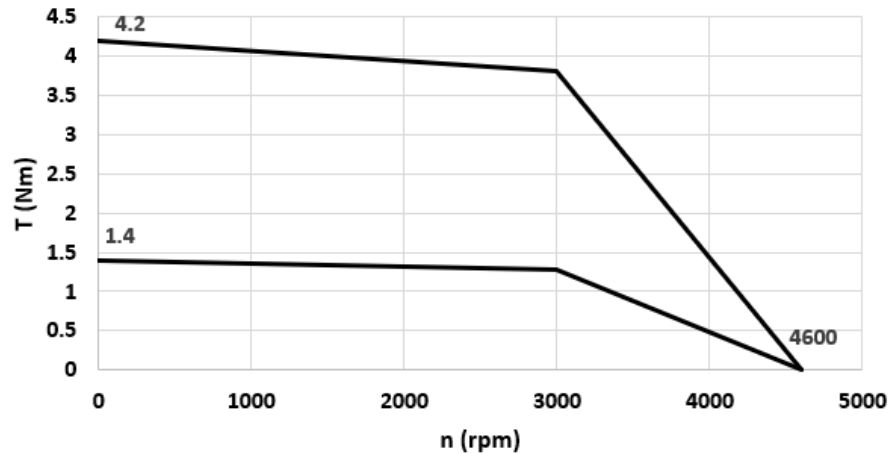

Housing:H66L6-04P
Terminal:T66L6-B

MOTOR CONNECTIONS		
Pin	Color	Signal
1	yel	U
2	red	V
3	blk	W
4	yel/grn	PE

PSM60-403026E2NL

