

Encoder connector - D-SUB HD 15 PIN

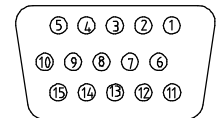

ENCODER	
VOLTAGE	+5 VDC ±5%
CURRENT	max. 200 mA
FREQUENCY	0 - 125 kHz
TEMP.	-20 - 40 °C
RESOLUTION	2500

### Motor Specification

Resistance	0.073 Ohm ±10%
Inductance	0.12 mH ±20%
Voltage	24 VDC
Rated Power	310 W
Rated Speed	3000 rpm
Rated Current	16.7 A
Rated Torque	1 Nm
Peak Current	50 A
Peak Torque	3 Nm
Ke (RMS)	4 V/Krpm
Rotor Inertia	0.48 kgcm <sup>2</sup>
Number of Poles	6
Weight	1.8 kg
Kt	0.066 Nm/A
Max Radial Force	180 N
Max Axial force	90 N

### Performance Curve

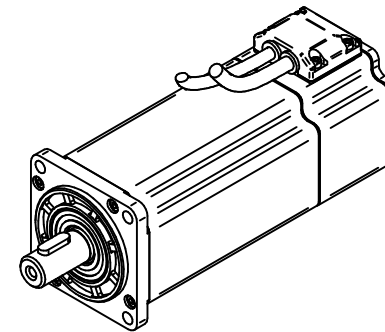
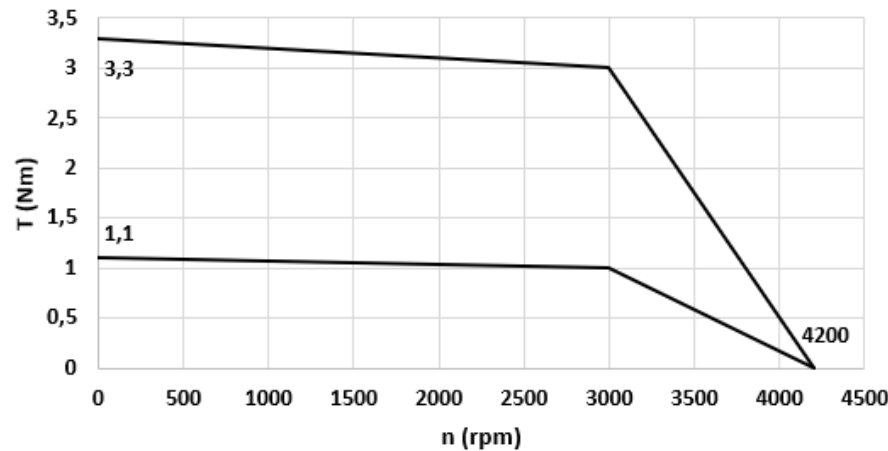

### ENCODER CONNECTIONS

Pin	Color	Signal
1	red	+5V
2	blk	GND
3	-	-
4	brn/blk	U+
5	brn	U-
6	yel	Z+
7	grn	B+
8	blu/blk	A+
9	gry/blk	W+
10	wht/blk	V+
11	yel/blk	Z-
12	grn/blk	B-
13	blu	A-
14	gry	W-
15	wht	V-

### MOTOR CONNECTIONS

Pin	Color	Signal
1	yel	U
2	red	V
3	blk	W
4	yel/grn	PE

# PSM60-3130B6E2NL