

# Technical Data

Number of poles	8
Rated Voltage	48 V
Rated Power	835 W
Rated Torque	1.33 Nm
Rated Speed	6000 rpm
Rated Current (RMS)	19.7 A
Maximum Torque	2.9 Nm
Maximum Current (RMS)	40 A
Standstill Torque	1.38 Nm
Standstill Current	20 A
Inductance line-line	0,35 mH ±20%
Voltage constant	4.7 V/krpm
Rotor moment of inertia	0.462 kgcm <sup>2</sup>
Isulation class	F
Weight	1.8 kg
Feedback device	Incremental encoder
	1000p/ rev
Cooling method	Totally enclosed non-ventiled
Protection level	IP65, shaft sealing IP54

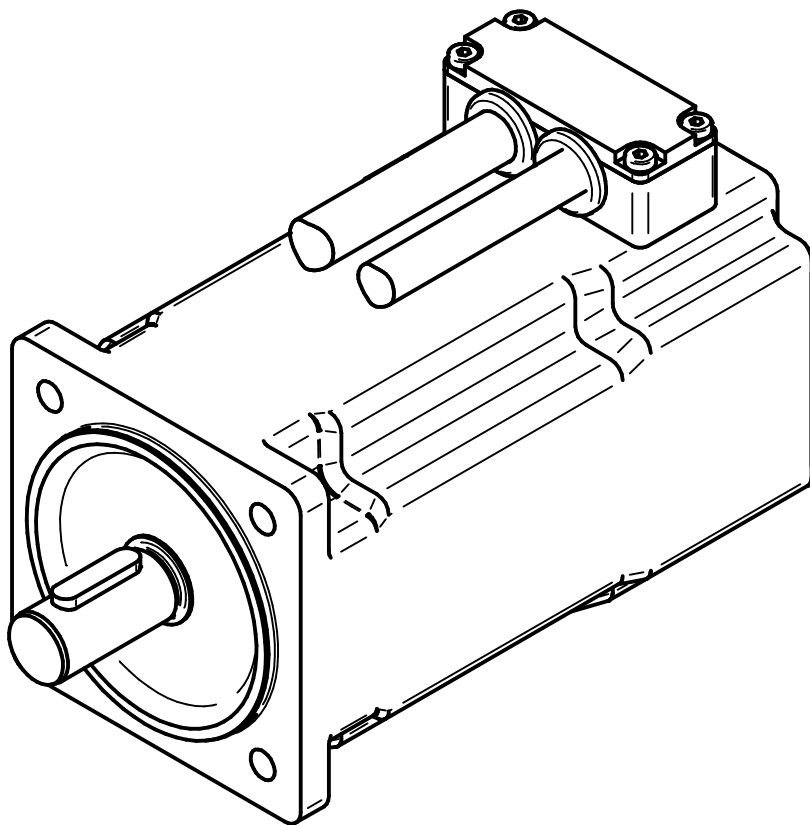
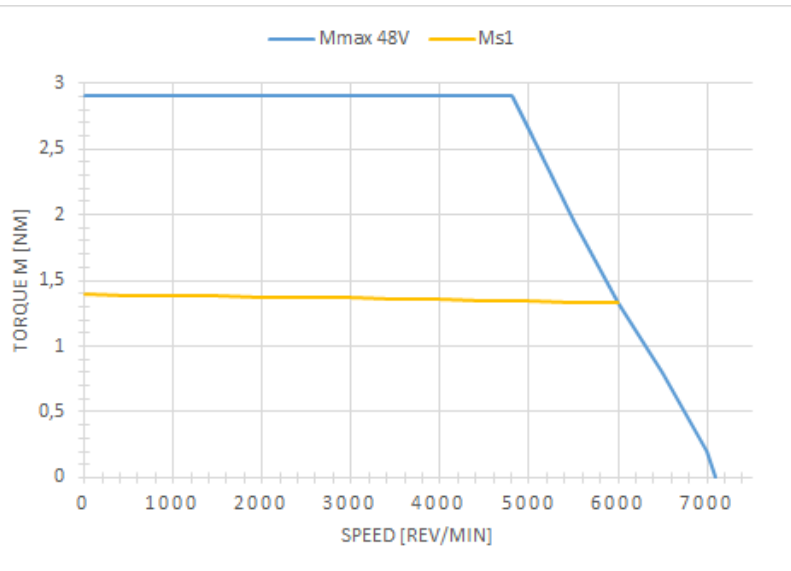

Environmental conditions	Temperature	-20°C to 40°C
	Humidity	Below 90%
	Environment	Far away active gas, combustible gas, oil drop, osh.
	Instalation altitude	UP TO 1000m:rated power above 1000m:15% power decreasing per 100m,max.400m
Rating Conditions	Mounting	
	Temperature	60K housing temperature rising at 40°C ambient

PSM72-8360A8E1NL-00

**Ultra  
Robotics**

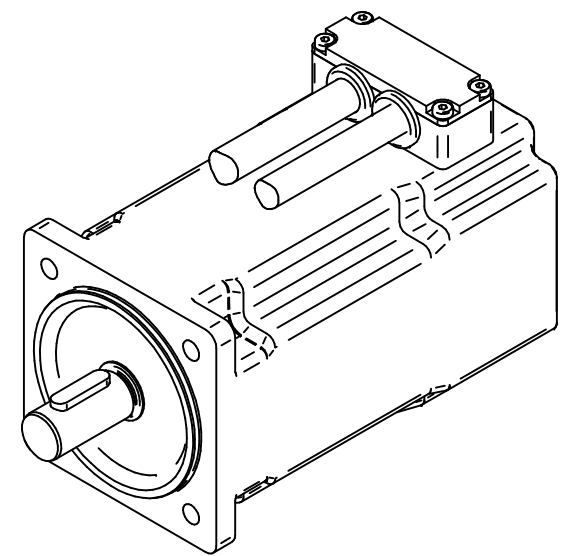
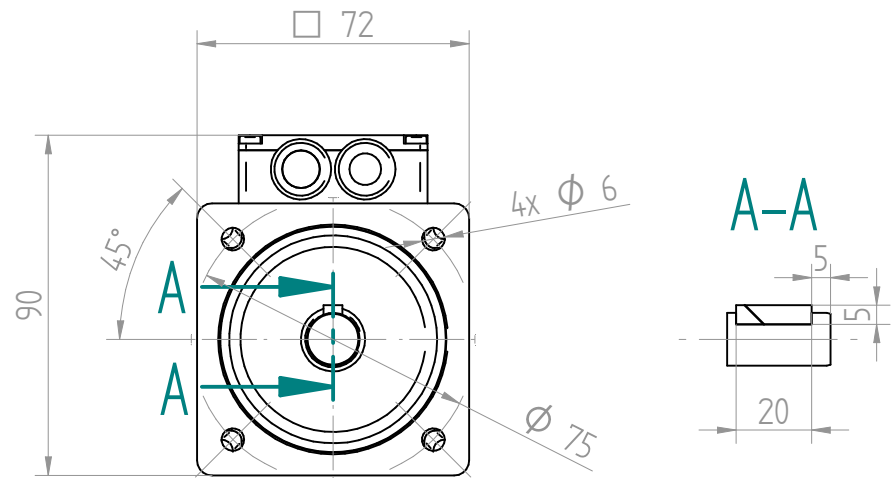
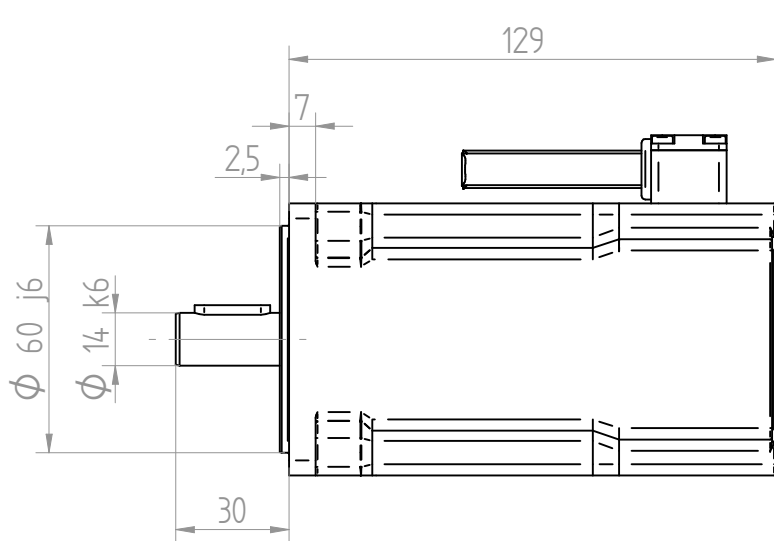

**ENCODER CONNECTIONS**

Pin	Color	Signal
1	whi	+5 V
2	brn	GND
3	-	NC
4	grn	U
5	yel	/U
6	gry	Z
7	pnk	B
8	blu	A
9	red	W
10	blk	V
11	vio	/Z
12	gry	/B
13	red/blu	/A
14	whi/grn	/W
15	brn	/V

D-SUB HD 15 pin

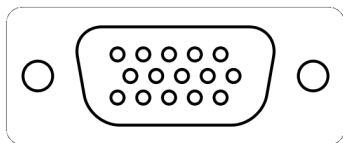

**POWER WIRE CONNECTIONS**

Pin	Color	Signal
1	1	U
2	2	V
3	3	W
4	yel/grn	PE
5	grn	shield

**PSM72-8360A8E1NL-00**

