

ENCODER	
VOLTAGE	+5 VDC ±5%
CURRENT	max. 200 mA
FREQUENCY	0 - 125 kHz
TEMP.	20 -100 °C
RESOLUTION	1000

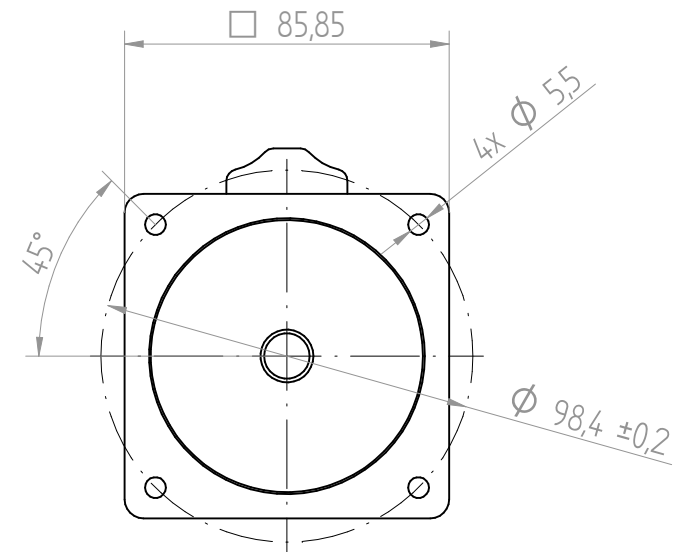

Motor Specification	
Resistance	Ohm ±10%
Inductance	0,19 mH ±20%
Voltage	36 VDC
Rated Power	627 W
Rated Speed	3000 rpm
Rated Current	24 A
Rated Torque	2.1 Nm
Peak Current	72 A
Peak Torque	6.3 Nm
Ke (RMS)	6.3 V/Krpm
Rotor Inertia	2.4 kgcm ²
Number of Poles	8
Weight	4.1 kg

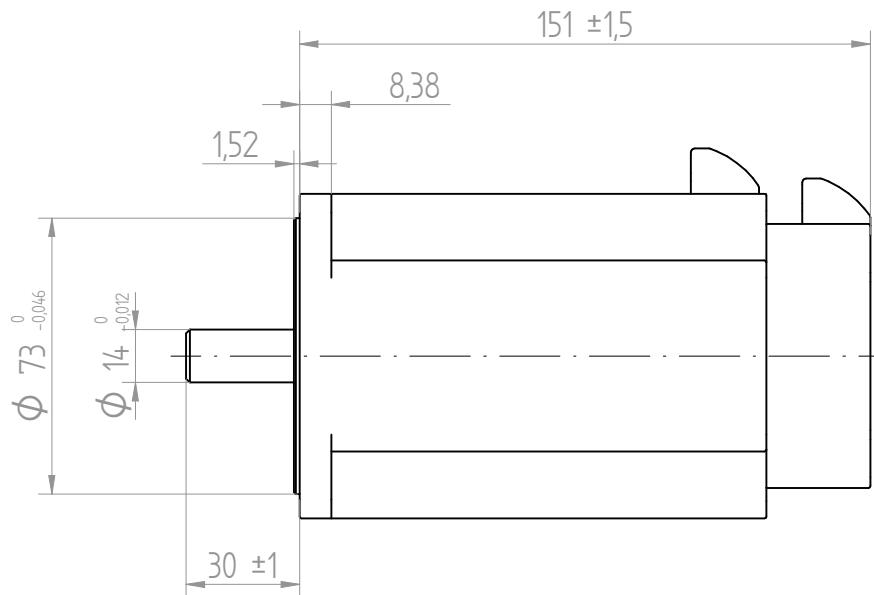
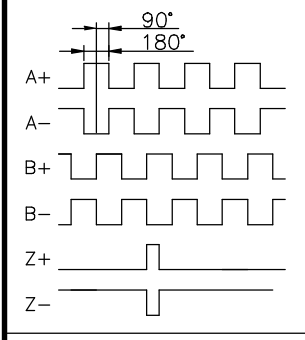
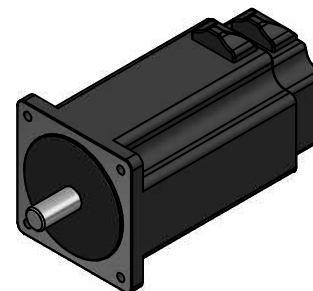
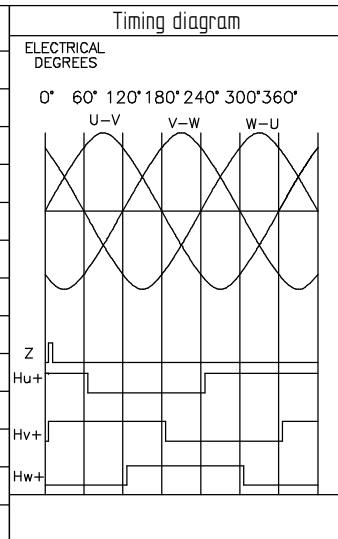

Encoder connector - D-SUB HD 15 PIN

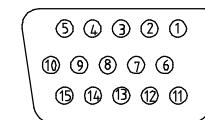

Motor phases

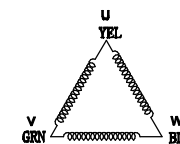

ENCODER CONNECTIONS

Pin	Color	Signal
1	red	+5V
2	blk	GND
3	-	-
4	yel	U+
5	yel/blk	U-
6	org	Z+
7	gry	B+
8	brn	A+
9	whi	W+
10	grn	V+
11	org/blk	Z-
12	gry/blk	B-
13	brn/blk	A-
14	wht/blk	W-
15	grn/blk	V-

MOTOR CONNECTIONS

Pin	Color	Signal
1	yel	U
2	grn	V
3	blu	W

PSM86-6230C8E1ND

POSITEC