

PM8SWS

MOTOR	Permanent magnet DC motor
PROTECTION	Totally enclosed (IP54)
GEARBOX	Worm spur (SWS)
MOTOR POWER	13 - 48 Watts
SPEED	1 - 101 rpm
VOLTAGE	12V - 220V DC available range
WEIGHT	1.55 kg
RADIAL LOAD	177 N
AXIAL LOAD	112 N
SHAFT TYPE	Single ended or double ended shaft as standard
EXTRAS	See page 36



See page 158 to specify shaft and gearbox position

Motor Power Cont. (W)		13	17	25	33	TORQUE (Nm)		
Motor Power 1 Hour (W)		15	21	33	40			
Motor Power 15 Min (W)		18	24	36	48			
Ratio Worm	Ratio Spur	MOTOR SPEED (rpm)				CONTINUOUS	1 HOUR	15 MINUTE
		1500	2000	3000	4000			
		OUTPUT SPEED (rpm)						
44	31.3	1	1.5	2	3	11	11	11
22 1/2	31.3	2	3	4	6	11	11	11
12 1/2	31.3	4	5	8	10	11	11	11
9 1/3	31.3	5	7	10	14	11	11	11
9 1/3	23.5	7	9	14	18	11	11	11
6 1/4	23.5	10	14	20	27	8	11	11
12 1/2	9.6	13	17	25	33	6	8	8
9 1/3	9.6	17	22	33	45	5	6	7
5 1/6	9.6	30	40	60	81	3	4	4
4 1/8	9.6	38	51	76	101	2.5	3	3.6

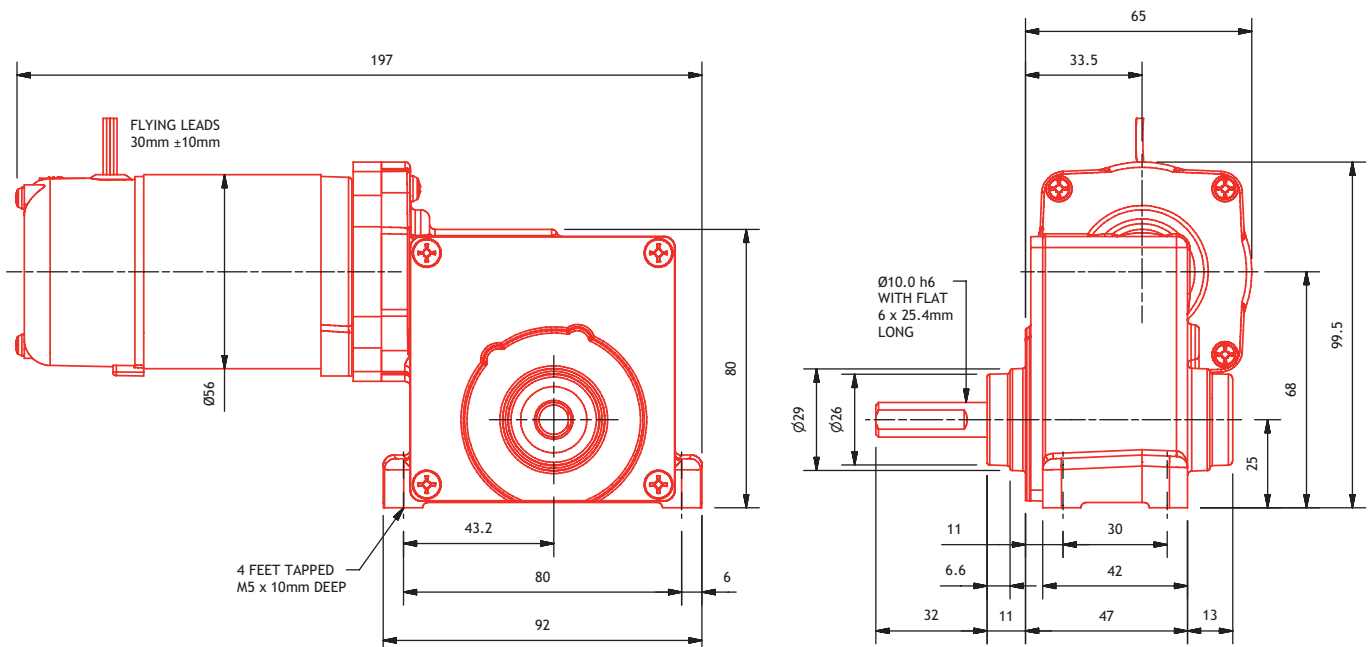

worm spur