

ENCODER	
VOLTAGE	+5 VDC ±5%
CURRENT	max. 200 mA
FREQUENCY	0 - 125 kHz
TEMP.	20 - 100 °C
RESOLUTION	1000

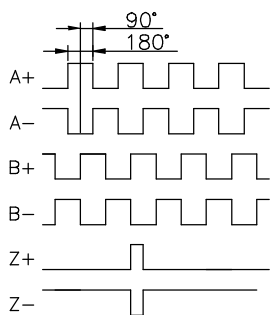

Encoder connector - D-SUB HD 15 PIN

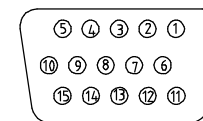

Motor phases

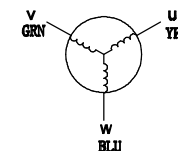

ENCODER CONNECTIONS

Pin	Color	Signal
1	red	+5V
2	blk	GND
3	-	-
4	yel	U+
5	yel/blk	U-
6	org	Z+
7	gry	B+
8	brn	A+
9	whi	W+
10	grn	V+
11	org/blk	Z-
12	gry/blk	B-
13	brn/blk	A-
14	wht/blk	W-
15	grn/blk	V-

Motor Specification

Resistance	13 Ohm ±10%
Inductance	30 mH ±20%
Voltage	310 VDC
Rated Power	313 W
Rated Speed	3000 rpm
Rated Current	1.4 A
Rated Torque	1.0 Nm
Peak Current	4.2 A
Peak Torque	3.0 Nm
Ke (RMS)	55 V/Krpm
Rotor Inertia	0.74 kgcm <sup>2</sup>
Number of Poles	8
Weight	2.3 kg

Timing diagram

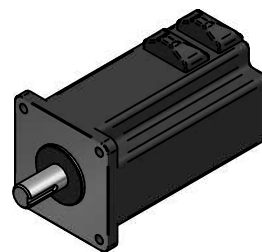
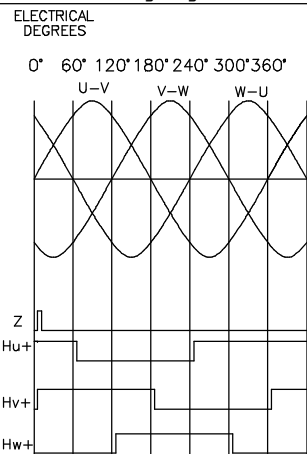

MOTOR CONNECTIONS

Pin	Color	Signal
1	yel	U
2	grn	V
3	blu	W

**PSM70-313028E1ND**

**Ultra  
Robotics**